

PassTest

Bessere Qualität , bessere Dienstleistungen!



Q&A

<http://www.passtest.de>

Einjährige kostenlose Aktualisierung

Exam : **200-120**

Title : CCNA Cisco Certified
Network Associate CCNA

Version : Demo

1. Topic 1, Operation of IP Data Networks

Refer to the exhibit:

```
Router1# show ip arp
```

Protocol	Address	Age(min)	Hardware Addr	Type	Interface
Internet	192.168.20.5	9	0000.0c07.f892	ARPA	FastEthernet0/0
Internet	192.168.60.5	8	0000.0c07.ac00	ARPA	FastEthernet0/1
Internet	192.168.20.1	-	0000.0c63.ae45	ARPA	FastEthernet0/0
Internet	192.168.40.5	9	0000.0c07.4320	ARPA	FastEthernet0/2
Internet	192.168.60.1	-	0000.0c63.1300	ARPA	FastEthernet0/1
Internet	192.168.40.1	-	0000.0c36.6965	ARPA	FastEthernet0/2

Data Frame:

Source MAC	Source IP	Destination MAC	Destination IP
0000.0c07.f892	192.168.20.5	0000.0c63.ae45	192.168.40.5

What will Router1 do when it receives the data frame shown? (Choose three.)

- A. Router1 will strip off the source MAC address and replace it with the MAC address 0000.0c36.6965.
- B. Router1 will strip off the source IP address and replace it with the IP address 192.168.40.1.
- C. Router1 will strip off the destination MAC address and replace it with the MAC address 0000.0c07.4320.
- D. Router1 will strip off the destination IP address and replace it with the IP address of 192.168.40.1.
- E. Router1 will forward the data packet out interface FastEthernet0/1.
- F. Router1 will forward the data packet out interface FastEthernet0/2.

Answer: A,C,F

Explanation:

Remember, the source and destination MAC changes as each router hop along with the TTL being decremented but the source and destination IP address remain the same from source to destination.

2.Refer to the exhibit.

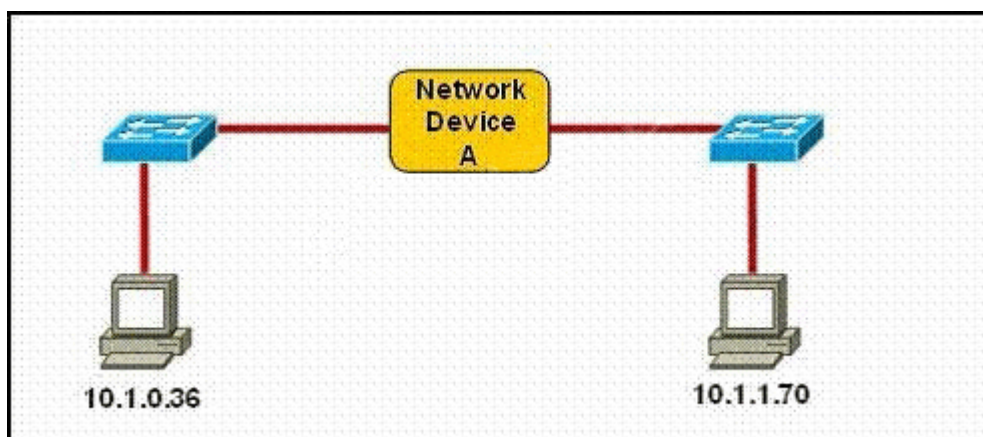

Which three statements correctly describe Network Device A? (Choose three.)

- A. With a network wide mask of 255.255.255.128, each interface does not require an IP address.

- B. With a network wide mask of 255.255.255.128, each interface does require an IP address on a unique IP subnet.
- C. With a network wide mask of 255.255.255.0, must be a Layer 2 device for the PCs to communicate with each other.
- D. With a network wide mask of 255.255.255.0, must be a Layer 3 device for the PCs to communicate with each other.
- E. With a network wide mask of 255.255.254.0, each interface does not require an IP address.

Answer: B,D,E

Explanation:

If Subnet Mask is 255.255.255.128 the hosts vary from x.x.x.0 -x.x.x.127 & x.x.x.128- x.x.x.255, so the IP Addresses of 2 hosts fall in different subnets so each interface needs an IP an address so that they can communicate each other.

If Subnet Mask is 255.255.255.0 the 2 specified hosts fall in different subnets so they need a Layer 3 device to communicate.

If Subnet Mask is 255.255.254.0 the 2 specified hosts are in same subnet so are in network address and can be accommodated in same Layer 2 domain and can communicate with each other directly using the Layer 2 address.

3 Which layer in the OSI reference model is responsible for determining the availability of the receiving program and checking to see if enough resources exist for that communication?

- A. transport
- B. network
- C. presentation
- D. session
- E. application

Answer: E

Explanation:

This question is to examine the OSI reference model. The Application layer is responsible for identifying and establishing the availability of the intended communication partner and determining whether sufficient resources for the intended communication exist.

4. Which of the following describes the roles of devices in a WAN? (Choose three.)

- A. A CSU/DSU terminates a digital local loop.
- B. A modem terminates a digital local loop.
- C. A CSU/DSU terminates an analog local loop.
- D. A modem terminates an analog local loop.
- E. A router is commonly considered a DTE device.
- F. A router is commonly considered a DCE device.

Answer: A,D,E

Explanation:

The idea behind a WAN is to be able to connect two DTE networks together through a DCE network. The network's DCE device (includes CSU/DSU) provides clocking to the DTE-connected interface (the router's serial interface).

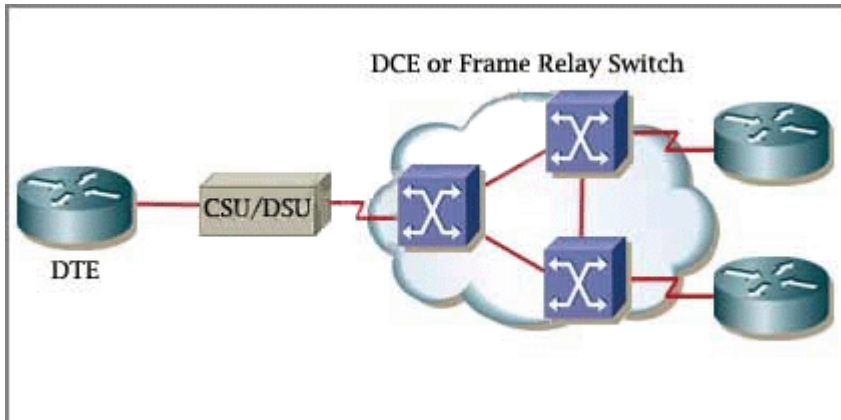

A modem modulates outgoing digital signals from a computer or other digital device to analog signals for a conventional copper twisted pair telephone line and demodulates the incoming analog signal and converts it to a digital signal for the digital device. A CSU/DSU is used between two digital lines. For more explanation of answer D, in telephony the local loop (also referred to as a subscriber line) is the physical link or circuit that connects from the demarcation point of the customer premises to the edge of the carrier or telecommunications service provider's network. Therefore a modem terminates an analog local loop is correct.

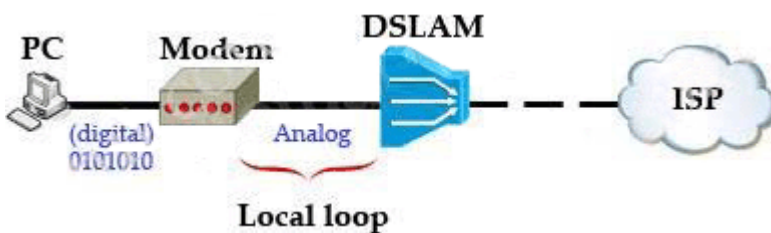

5. Refer to the exhibit.

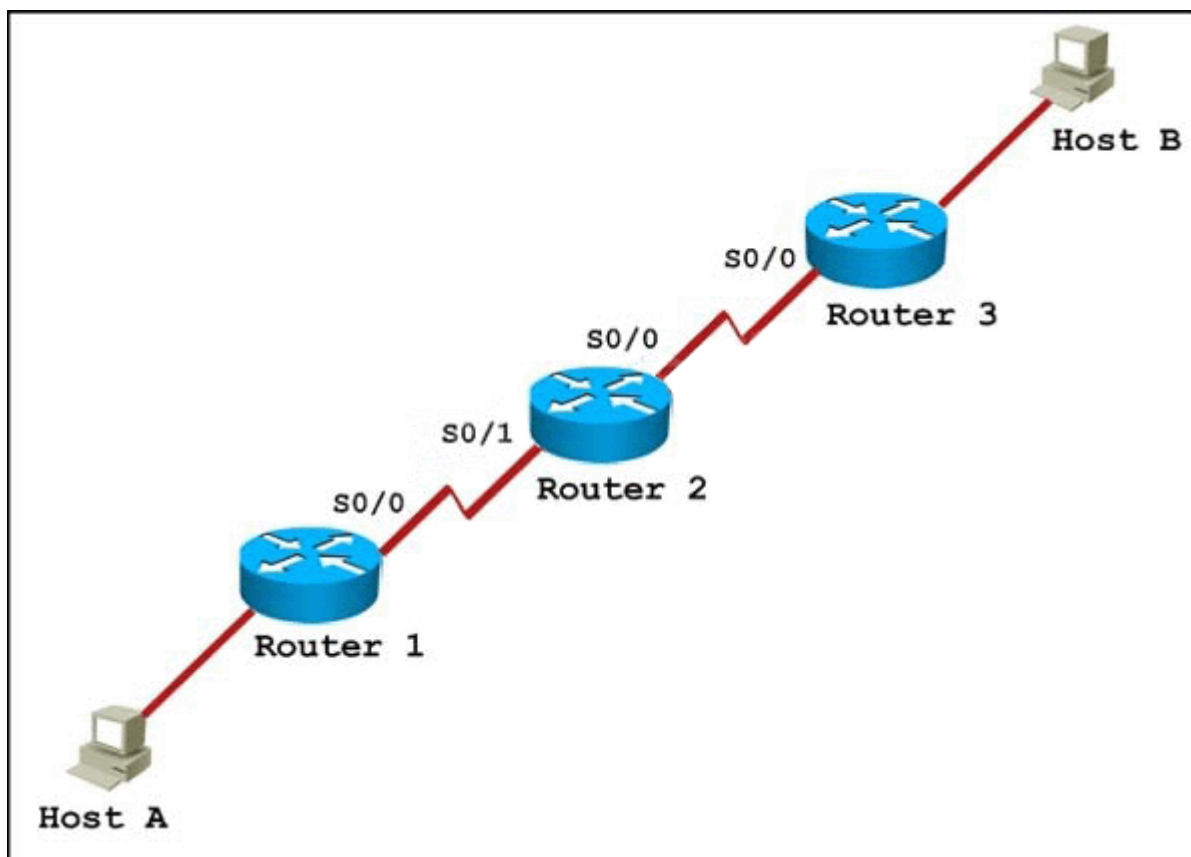

Host A pings interface S0/0 on router 3.

What is the TTL value for that ping?

- A. 252
- B. 253
- C. 254
- D. 255

Answer: B

Explanation:

From the CCNA ICND2 Exam book: "Routers decrement the TTL by 1 every time they forward a packet; if a router decrements the TTL to 0, it throws away the packet. This prevents packets from rotating forever."

I want to make it clear that before the router forwards a packet, the TTL is still remain the same. For example in the topology above, pings to S0/1 and S0/0 of Router 2 have the same TTL.

The picture below shows TTL values for each interface of each router and for Host B.

Notice that Host A initializes ICMP packet with a TTL of 255:

